

## **Mailbox Policy for the Town of Garland**

For convenience and practicality, mailbox installations have been allowed within the right-of-way of Maine's public highways; however it is important to recognize that such installations have two very important conditions:

- 1) The mailbox must be installed in accordance with applicable standards to ensure that mail can be delivered and that the mailbox does not create an obstacle or safety hazard to those that use or maintain the highway, and
- 2) The mailbox is installed entirely at the owner's risk. In other words, if the mailbox incurs damage during any sort of highway operations or maintenance, the property owner is not entitled to replacement or compensation. In fact, if the mailbox was not installed in accordance with the applicable standards as stated above, the owner may even be held liable for injuries or damages that may have been incurred as a result.

Mailbox design and installation standards are available from several sources, and mailbox owners are expected to consult this information prior to undertaking any mailbox installation or replacement. The following standards have nationwide relevance and were developed in cooperation with one another:

- The United States Postal Service (USPS) Mailbox Guidelines. The USPS defines the standards for mailbox construction, as well as the placement tolerance that must be met to accommodate postal operations. Specifics may be obtained from your local post office or online at: <https://www.usps.com/manage/mailboxes.htm>
- American Association of State Highway and Transportation Officials (AASHTO) Roadside Design Guide. The AASHTO Roadside Design Guide, Chapter 11: *Erecting Mailboxes on Streets and Highways* deals with the safety and construction of privately owned mailboxes, mailbox supports, and mailbox turnout designs and is less focused on postal operations. This publication may be obtained online through the AASHTO Bookstore at: [https://bookstore.transportation.org/Item\\_details.aspx?id=1807](https://bookstore.transportation.org/Item_details.aspx?id=1807)

In addition, if the mailbox is to be installed in an area with sidewalks, it is important to recognize that the sidewalks must continue to comply with ADA requirements:

- American Disabilities Act (ADA). The most current version of the ADA Standards for Accessible Design set forth the minimum requirements to ensure facilities are readily accessible to and usable by individuals with disabilities. <http://www.ada.gov/regs2010/2010ADAStandards/2010ADAstandards.htm#c4>

The municipality has developed this policy to promote compliance with these national standards and to help further clarify the expectations and responsibilities of Maine mailbox owners. Such compliance helps us ensure that we continue to provide safe, efficient and accessible highways for all. The following pages further specify the details associated with mailbox height, location, offset, and post type to minimize the potential hazards and conflicts associated with mailbox installations and to reduce the opportunities for damage to mailboxes.

### ***Mailbox Installation Standards***

#### **General Location:**

Whenever possible, your mailbox should be located after your driveway opening. This location placement improves visibility, minimizes the amount of snow that comes off of the snow plow, and improves the approach for your mail carrier. The diagram below further clarifies this preferred placement:

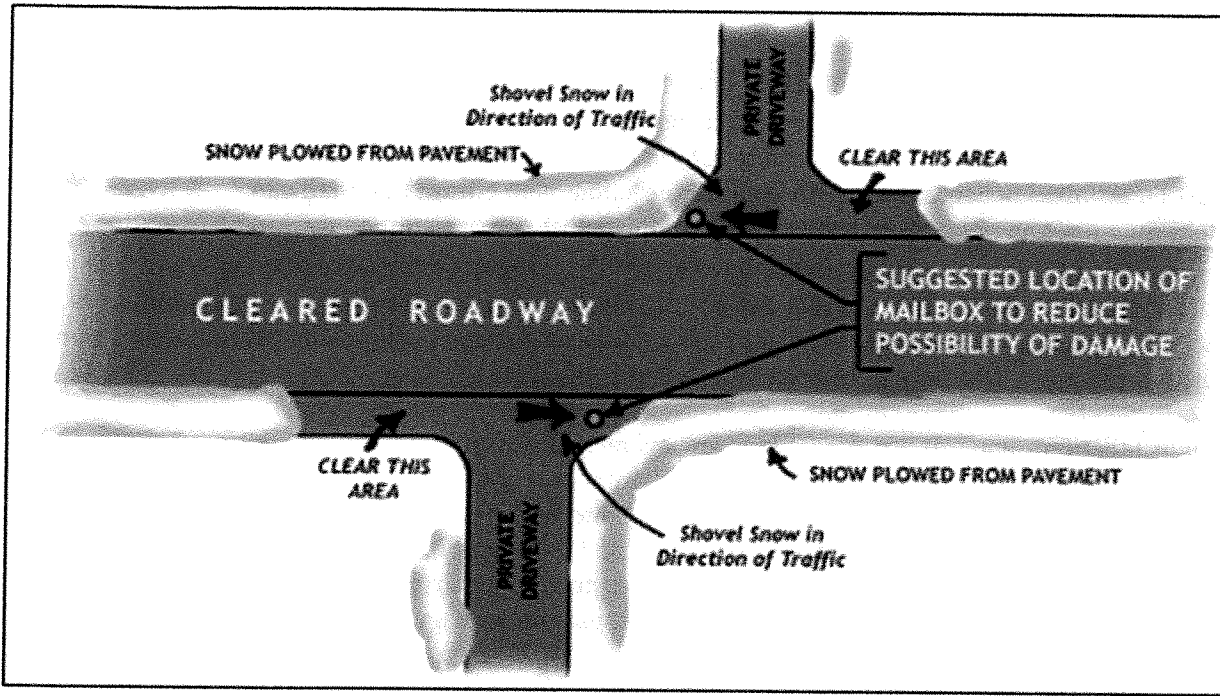

**Mailbox Support Design:**

In many cases, it is best to use an extended arm type of post with a free-swinging suspended mailbox. This allows snowplows to sweep near or under boxes without damage to supports and provides easy access to the boxes by carrier and customers. The following picture shows a free-swinging suspended mailbox:



In addition, note the strategic placement of the red reflector on the point closest to the road. This will help your local snowfighter see and avoid your mailbox during winter storms.

**Offset:**

Mailboxes should be set back from the edge of the shoulder – regardless of whether the shoulder is gravel or paved. In other words, the face of the mailbox should be at least **one foot (1')** back from the edge of the normally plowed surface of the highway or the face of curb. Greater offset distances are encouraged whenever possible to allow the mail carrier to get further out of traffic and to further minimize potential damage to your mailbox. The following picture shows a mailbox with a reasonable offset:



Mailboxes in sidewalk areas should leave at least 36" behind the back of the box or the post, whichever is located the furthest from the road.



**Height:**

According to USPS standards, a mailbox must be installed with the bottom of the mailbox located between 41" and 45" high above the surface of the highway shoulder. We recommend that this height be closer to the 45" measurement to minimize conflict with the height of the plow truck wing when snow is being pushed back during, or between, winter storms. The following picture further clarifies the height considerations:

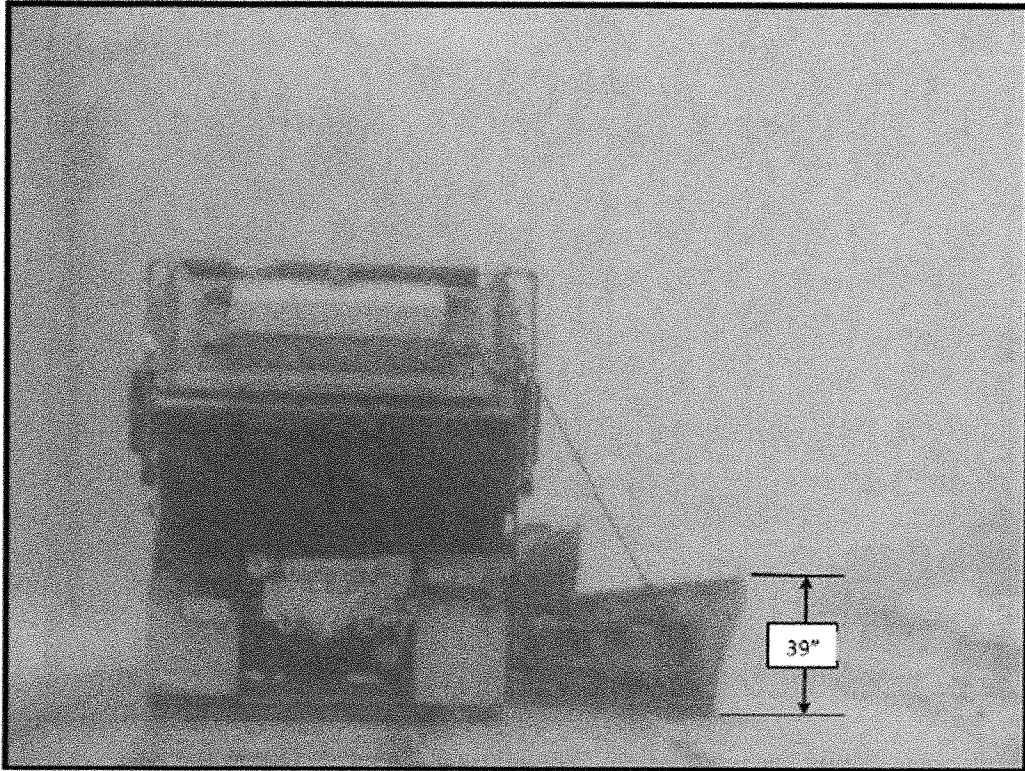

**Post Size, Type and Embedment:**

Mailbox posts must be sturdy enough to hold up the mailbox in all types of weather conditions, however they cannot be so rugged that they present a hazard to vehicles that inadvertently leave the road. If a mailbox support is struck by a vehicle, it must easily break away. Therefore, the following types of posts are deemed acceptable:

• **4" x 4" wooden posts** embedded **2 feet** into the ground. Larger wooden posts (4" x 6" or 6" x 6") may be used only if the post is drilled through with an appropriate spade bit to create a shear plane. The following diagram indicates the necessary holes and spacing.

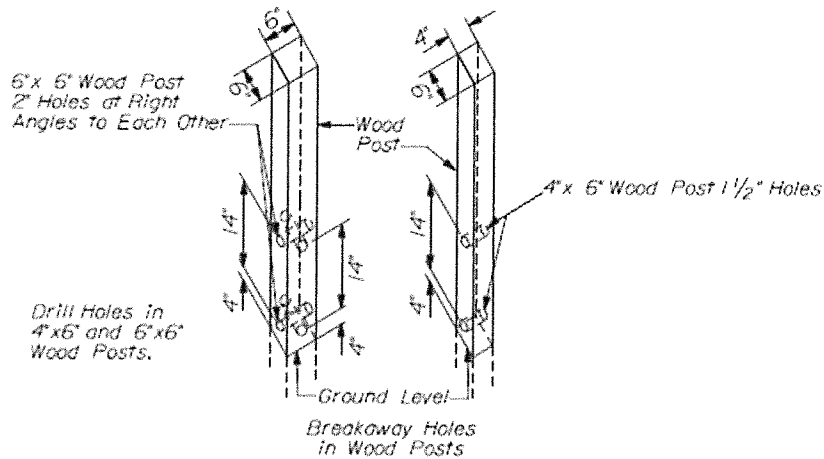

• **1" to 2" round diameter steel or aluminum pipe or standard U-channel post** embedded **2 feet** into the ground.

• Unacceptable mailbox supports include: anything that is filled with concrete, masonry and stone structures, heavy steel structures, and most objects that were intended for other uses (e.g. antique plows, I-beams, and various other household tools and objects).

**NOTICE: Mailboxes, attachments or support systems not consistent with this policy are considered "Deadly Fixed Objects" (aka. "DFOs") and are in violation of 23 MRSA §1401-A on state and state aid roads. On local roads, they can be considered as "obstructions" and a number of statutes relate to these obstructions. As such, when these installations are recognized by the municipality, the owner will be informed of the hazard and immediate removal will be requested. If the property owner does not comply with this request, the municipality may elect to remove the installation and seek reimbursement from the property owner for all costs incurred.**